



USER MANUAL

DIM AC-D2

DIN

DIMMER

v2.20

The dimmer designed for DIN rail mounting, has two tracks Mosfet control receivers 2x460VA or 2x460W smoothly in the range of 0-100%, the analyzer current drawn by the receivers 230V~ and is designed for installation in cabinets on DIN rails or enclosures controlled devices.

It is possible wireless connectivity (Zee) or wired (Wee) system. The unit can control 2 keys mosfet, maintenance equipment 1wire, i2c, communication devices 0..10V (depending on the version outputs / inputs). The device can be depending on the version supplied from the bus Wee 5V~ or 12V~.

You can select the slope Trailing or Leading Edge, and a soft start (start time and slope configurable).

The device allows you to control energy saving light bulbs, motors, fluorescent lamps.

Explanation of symbols

- The flash symbol indicates the danger of electric shock
- The symbol indicates another danger that may occur while still incorrect

Safety rules

Be sure to read the instruction manual. The device should be used as you intended. In the case of use of the device misuse, or failure to comply with the following instructions, the manufacturer accepts no liability for any damage to property or to the person and the guarantee / warranty expires.

The device must be connected to single-phase in accordance with applicable standards. This manual defines the connection. Activities relating to the installation and connection should be done by qualified installers electricians after reading this instrukcja.

Disassembling of the device and its damage will void the warranty, and pose a risk of electric shock. Before assembly, make sure that connecting cables are not powered.

Technical data

supply voltage 4,8..6~

contact load 2x2A/230V~ or 2x2A/30V~
 working temperature -10°C..+35°C
 max operating temp max +130°C
 operating frequency 2.4GHz DSSS, 16channels ISM

comply with the Directives RTTE

dimensions 90 x 35 x 65 mm (2din)
 energy consumption <0.100W for power Wee
 max
 radio coverage ~ 30m in the building
 ~ 300m in the field
 cable range ~ 500mbus length
 Transmission protection AES 128bit encryption
 PIN for every unit
 Weight 103g

0..10V configuration n0..n3 4xIN
 Current measurement -

The device is equipped with a cooling fan should be installed so that the air intake fan (indicated by the arrow "ventilation" in Figure 1) was not obscured. Direction "mountain" of Fig. 1 should be facing up when installing the device.

I Automation system

ZeeGO is a building automation system, in which the device can be connected to the main cable (Wee) or radio (Zee).

Radio equipment to build a network of MESH (grid), where typically each network node can transmit data on, and in case of its failure or shutdown, the network will rebuild automatically.

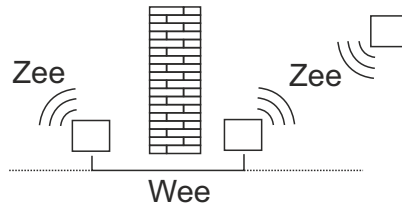

The radio signal is attenuated by any obstruction such as a wall or housing, applying in the case of wires improves call quality, and also eliminates cumbersome loss of communication, through the complete stability of the connection. In a wired network, you can connect wired devices 255.

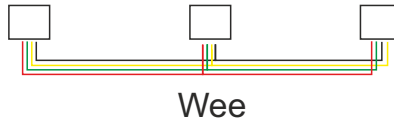

Wee wires are connected in parallel, and each device connected by wire, can build independent radio networks available on 16 channels, each radio network can connect 255 radio devices.

The transmission is bi-directional with confirmations and repeats the message is encrypted with AES with 128 bit key, each device has its own individual PIN number needed to connect with the panel in the full encryption and a unique Serial Number.

Radio transmission takes place in a free 2.4GHz band on one of the 16 channels. The high sensitivity devices provide error-free transmission even in highly disturbed environments.

DIMMER device allows you to control one track mosfet based on user scenarios, and the combination of 2 keys mono / bi stable inducing scenarios, as well as a number of external sensors on the many available connections. All these features are available regardless showing the huge potential of the device.

The device DD2 DIMM controls two tracks mosfet based on user scenarios, and the combination of 4 devices 0..10V (depending on the version of the input / output) inducing scenarios, as well as a number of external sensors on the many available connections. All these features are available regardless showing the huge potential of the device.

Typically the device is intended for installation in the control cabinet on a rail din, offering additionally:
 - A combination of sensors bus 1wire: thermometers
 - The combination of interfaces for analogue control 0..10V
 - I2c connection of sensors: humidity, pressure, light, temperature, zoom and more

Each of the events can be used to build the appropriate system response.

The installation must have a constant supply Isolator bipolar separation joint that at least 3mm.

II Installation of the unit

- The device should be installed after disconnecting the power phase. Make sure that cables are not under voltage.
- The behavior of the order indicated connections, allows for correct installation.

- Note of the card PIN and Serial Number (SN) device (Both located on the housing of the device)
- Connect the high voltage cables N, L, o0, o1 as on Fig.1

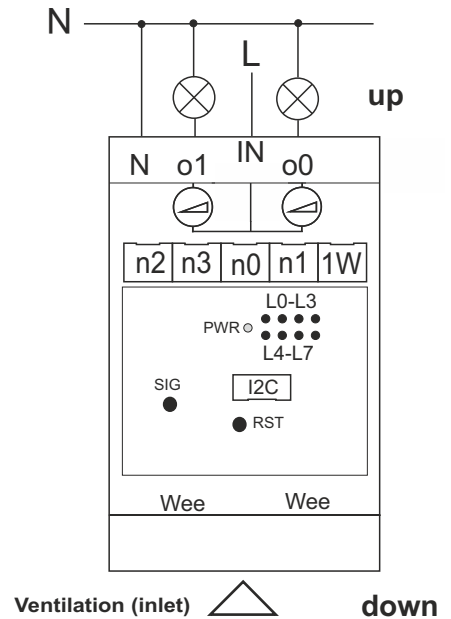

Fig 1. Connection diagram for dd2dimmm

- Explanations to the scheme:
 N - terminal neutral conductor
 L - terminal phase conductor
 o0, o1 - power receivers terminals
 SIG - indicator light status
 PWR - power light bus
 RST - service button to reset the device
 1W - 1-wire bus connector
 I2C - i2c bus connector
 n0..n3 - connectors 0..10V
 L0..L7 - the state of the line signal (0, 25, 50, 75, 100%)
 Wee - Wee bus connector
 CFG - configuration jumper bus voltage Wee

- Connect the device 0..10V

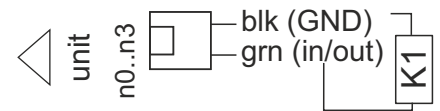

Fig.2 Wiring diagram keys to the connectors 0..10V

- Explanations to the scheme:
 n0..n3 - 0..10V connector for coupling modules
 K1..Kx - coupled modules
 cable colors: grn - green (signal), blk - black (ground)

- Configure jumper CFG bus voltage Wee

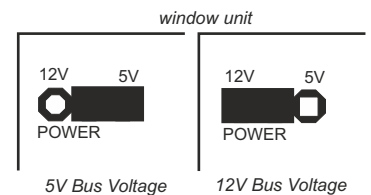

Fig. 3 CFG - Jumper configuration bus voltage Wee

- Put the plug A0..A3 in the connector 0..10V module.
 - Insert the plug in the socket sensor 1Wire 1W, I2C plug into the socket I2C bus Wee Wee.
 - Put module distribution being careful not to damage the cables, high voltage cables arrange so as not to interfere with the module. This operation requires some practice, it is recommended to perform the installation by trained personnel.
 - Close the switchboard by structure.
- From the moment the device is not connected to the system will operate in emergency mode;

III Launching Device

It is recommended that a system configured by connecting all devices, facilitate system configuration.

1. Plug the control unit of the system, according to the instructions to connect the control unit.
2. Turn on the control unit



All the following activities will be carried out using the UI in short called UI.

USER INTERFACE (UI) - is the means of user access to the system (eg. A mobile phone)

3. UI - Select option Discovery

The control device begins to recognize and build a network after the completion of this process will be presented to the relevant report

4. Select the device you want to connect, and when prompted by the system give the PIN for each of them.



Since then, the link will no longer work in Safe mode, unless the panel will be available. In the case of loss of communication **EMERGENCY MODE** is activated.

5. UI configure the functions available using the wizard FUNCTIONS.

6. UI configure operational scenarios using the wizard SHARES.

A detailed description of configuring the system. is presented in the manual control system and on the website of the system.

Available output signals 0..10V:

- Read the status of the port n0..n3 / 0..100% (for inputs)
- Snapshot port n0..n3 / 0..100% (for outputs)

Available input signals of sensors:

Depending on the configuration, are available:
The reading, change of reading, the frequency of reporting changes, the size of the reported value changes
This applies measured values: light (lux), close (%), temperature (C), humidity (%), pressure (hPa), others.

Available input signals, output keys fet:

- Status%, delay time, rise / fall time
- The current drawn by the load, changing the current received

IV Operating status, Reset

Operating status is signaled by the indicator light, which the state can be seen looking in the window service SRW.

State service work is signaled by a flashing lamp:

- The light flashes 8 times per second - no connection to the network,
 - Flashes 1 time per second - a network connection
- After connecting to the network, the light stops blinking, the device is in normal operating mode.

The unit can be restarted by pressing the service button (insert a thin object in the window RST)

- Short press will restart the machine (the LED blinks slowly once and then quickly 2x)
- Pressing long (more than 2 seconds) will cause a reset (erasure of key memory network), will introduce the device in service mode - it will be possible to join the unit to another network.

V Warranty

TERMS OF WARRANTY:

1. The guarantor of the quality of the device is Zeegroup Sp.zo.o. (Hereinafter referred to as the "Guarantor" registered in Poland, Lodz, ul. Tuwima 6, 90-010)
2. The guarantor shall provide a guarantee for the device - in the case of individual customers is 24 months, while in the case of business customers (who purchase their devices in connection with or for the purposes of the business) 12 months. This term is calculated from the date of delivery of goods to the Client.
3. The warranty covers the liability of the Guarantor for the malfunction of equipment due to its physical defects, which have stood for reasons inherent in the Device and revealed within the warranty period.
4. The warranty is valid on Polish territory.
5. During the warranty period, the Guarantor undertakes to remove the defects of physical devices by:
 - a) make the free repair devices, including exchange any defective or damaged parts or parts with new or reconditioned and free from defects or
 - b) replacement of equipment at the new and free from defects.The right to choose how to remove physical defects devices exclusively to the Guarantor and is solely at his discretion.
6. If the device is to offer the Guarantor reserves the right to exchange for other devices, with similar parameters currently available from the Guarantor. This is an implementation of the obligations of the Guarantor.
7. As part of the guarantee client does not have permission to withdraw from the agreement of sale devices and reclaim money paid for the device.
8. Client with a valid warranty document makes the complaint Guarantor devices via the form on the following website zeego.pl or Authorized Representative in person or by telephone. List of Authorized Representatives of containing their addresses and telephone numbers has been posted at www.zeego.pl.
9. After the adoption of the complaint by the Guarantor, will issue a confirmation of the customer complaint, which will be given individual notification number (RMA). In case of filing a complaint through the Authorized Representative of the Guarantor, this will contact the customer to confirm forwarding the application to the Guarantor and provide information about that number RMA.
10. After receiving the complaint Guarantor shall immediately contact the customer to determine the date at which the representatives of the Guarantor will make an inspection and evaluation of technical devices in the presence of the customer.
11. After inspection the customer will be informed about the date and manner of handling the complaint. Repair or replacement equipment should take place no later than 14 days with the proviso that the fact that all components of the devices are covered by the manufacturer's warranty, the duration of the warranty can be extended by the time waiting for a replacement component by its manufacturer.
12. indicated in point 2 of the warranty period is extended by the time during which repair or replacement were performed, and the customer was prevented from using the devices.
13. Travel costs for faulty equipment, or the cost of transportation to the place of repair cover Guarantor. Where it is found that the disadvantages of devices arise from circumstances for which the guarantor is not responsible, then the guarantor may charge these costs Buyer.
14. The guarantor may refuse to accept a complaint if it finds that the customer does not have a valid warranty or malfunction of devices due to reasons other than a defect inherent physical devices in the Device, in particular those mentioned in section 15.
15. The warranty does not cover:
 - a) mechanical defects of devices, including cracks, fractures, cuts, abrasions, physical deformations caused by impact, fall or dropping on a device other object;
 - b) operation incompatible with the intended devices, manual devices, or the manufacturer or the Guarantor;
 - c) damage or defects caused by the fault of the user, or third parties;
 - d) damage caused by external causes, not previously inherent in the Device, including force majeure;
 - e) damage caused by the impact of weather conditions on the device;
 - f) damage caused by power surges and power supply, a faulty connection to the power grid and the use of incorrect fuses;
 - g) damage caused by improper maintenance or lack of maintenance equipment,
17. This warranty does not exclude, limit or suspend the rights of the Customer arising from the provisions of the warranty for defects in the goods sold.

Utilization



Electronic devices are recyclable waste and must not be disposed of in the trash. Products must be disposed of after the operation in accordance with applicable law.

Distribution

Zeegroup Sp. z o.o.

Zeego.pl

Zeego.eu

If you have questions, please contact your local representative.



R1.0



Made in EU